



COVERED DOUBLE LIGHTS

Take every room from ordinary to extraordinary with Paklite Double Covered Light fixture. A handsome light designed for extra light out put available in 4ft double rod utility. As it is outfitted with extra safety & shape, it is extensively used where quality standards are preferred.



CDL240-Transparent

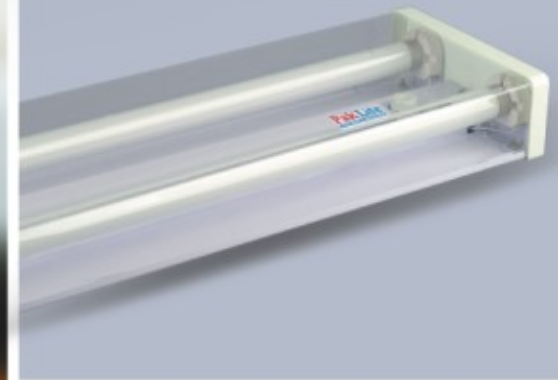

APPLICATIONS

- Food Industries
- Pharmaceutical Industries
- Hospitals
- Staff Rooms
- Show Rooms
- Computer Labs
- Display Centers
- Drawing Rooms
- Reception Areas
- Executive Offices
- Shopping Centers

COVERED DOUBLE LIGHTS

FEATURES

- Elegant shape.
- Flickering white powder painted body.
- Upper cover available in diamond, crystal clear & milky glass.
- Extra quality standard wiring & pre-fitted Paklite quality ballast.
- Color matching sides made up of A.B.S. plastic for decent look.
- Specially designed for ISO requirement, and also meets the quality standard of Food & Pharmaceutical Industries.

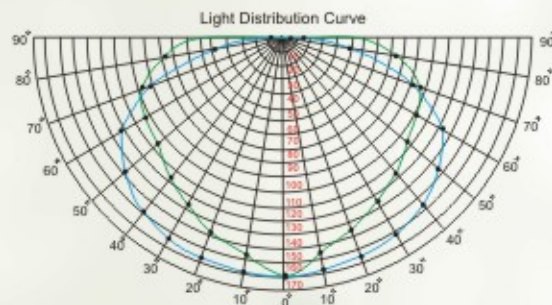

SPECIFICATIONS:

Item Code	Description	Length	Width	Height	Watts	Screw Distance	Amp.
CDL240 DIAMOND	Cover Double Light 4ft. for 2X36/40 Watt Lamp with Diamond Type Cover	1235	175	92	80	895	0.86
CDL240 TRANSPARENT	Cover Double Light 4ft. for 2X36/40 Watt Lamp with Transparent Type Cover	1235	175	92	80	895	0.86
CDL240 MILKY	Cover Double Light 4ft. for 2X36/40 Watt Lamp with Milky Type Cover	1235	175	92	80	895	0.86

Design & dimension are subject to change without notice.

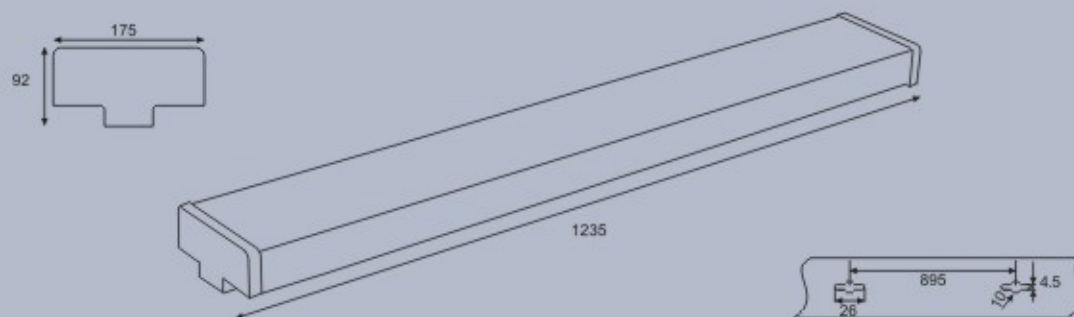

CDL240-Diamond

